

## Formation of Mini Cluster

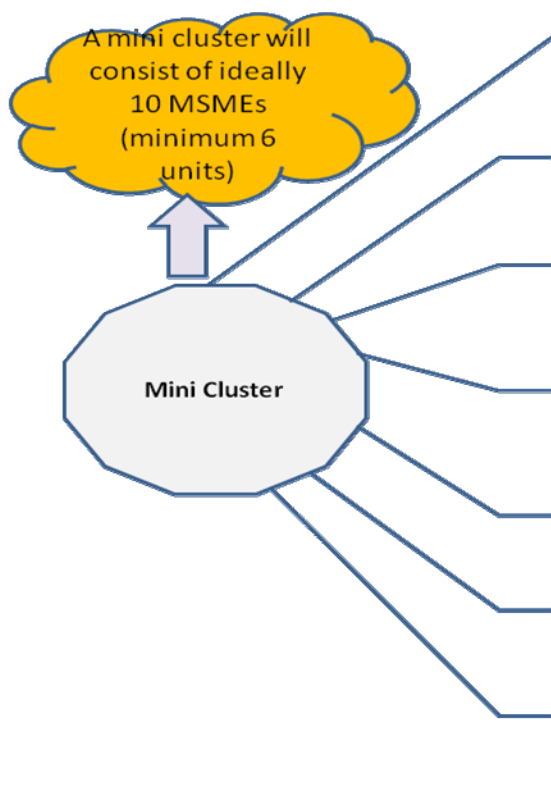
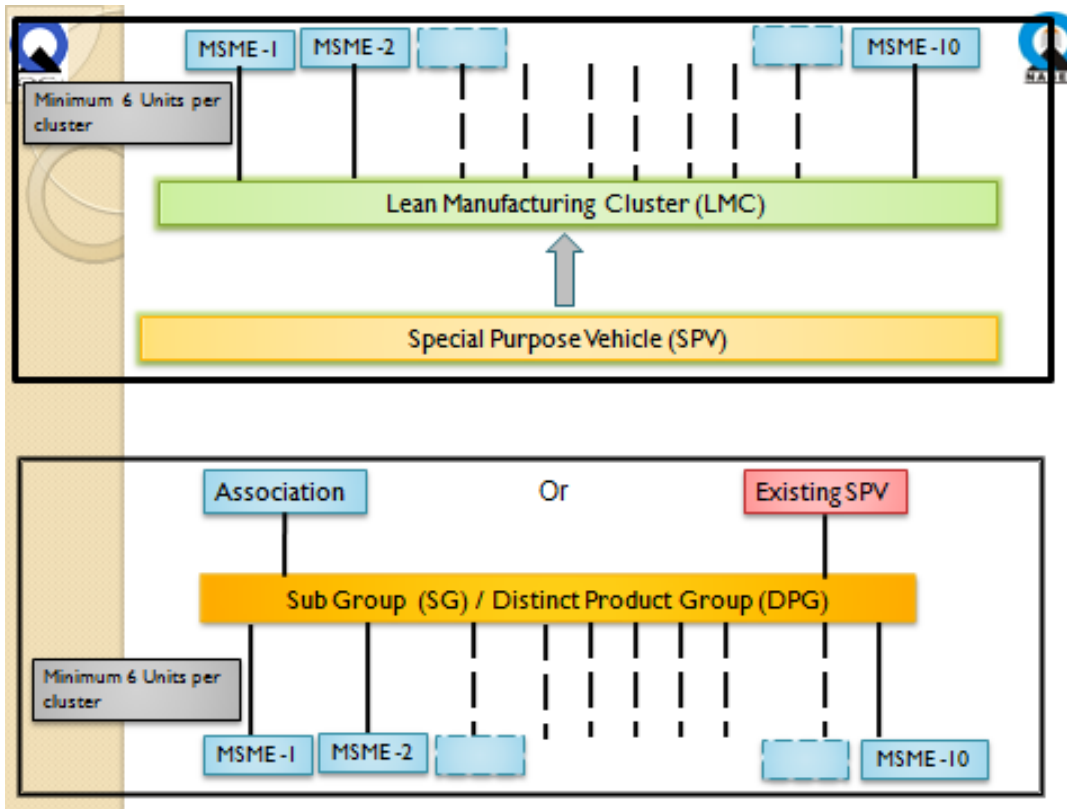

Mini Cluster is a group of preferably 10 MSME's located within an identifiable and as far as practicable, contiguous area and manufacturing same/ similar products.

A mini cluster may be formed by a new SPV or as Sub Group / Distinct Product Group of an Association or Existing SPV.

In case SPV is not available in the cluster, the scheme may be availed through another legal entity i.e. concerned association by grouping the MSMEs in the form of Distinct Product or Sub Groups

DPG and SG will be small groups within Association or existing SPVs, formed with the approval of Management of SPV or Associations as the case may be.

All the units of MC would work with Assigned Lean Manufacturing Consultant to implement specific Lean Techniques.

In case the scheme is being availed by SPV ( existing or new), a separate joint Bank Account will be opened in a National Bank for receiving the funds from NMIU.

In case DPG/ SG is formed for taking benefit of the scheme, the project specific account will be operated jointly by Head of SPV or Association and the Nodal officer of DPG/ SG.